

PRS[®]

Proportional Rinse System



**Wasting of water and
electricity damages
the environment**

Comenda: a history of technological innovation

The founder company of the ALI Group, the name of Comenda has been synonymous with the best in professional dishwashing equipment for over 40 years. One of the European and world leaders in this sector, Comenda manufactures and sells more than 200 washing solution models, from small glass and cup washers for bars to large automated continuous-feed systems for hospitals, canteens, hotels and in-flight catering.

Savings with Comenda

Comenda accentuates its technological lead with the patented innovation **PRS (Proportional Rinse System)**.

Rack or flight conveyor machines operate at different speeds and use the same amount of rinsing water regardless of the speed selected.

This is illogical and unjustifiable. If the rinse is satisfactory with X litres of water consumed at the top speed, there is no reason to utilise the same quantity at

lower speeds when output is generally 30% lower.

The dishes must be rinsed with the right amount of water according to the speed of the machine. This is now possible with the PRS system.

In these conditions PRS also produces energy savings of 30% and saves rinse water, detergent and rinse aid. This is the great advantage of the PRS System.

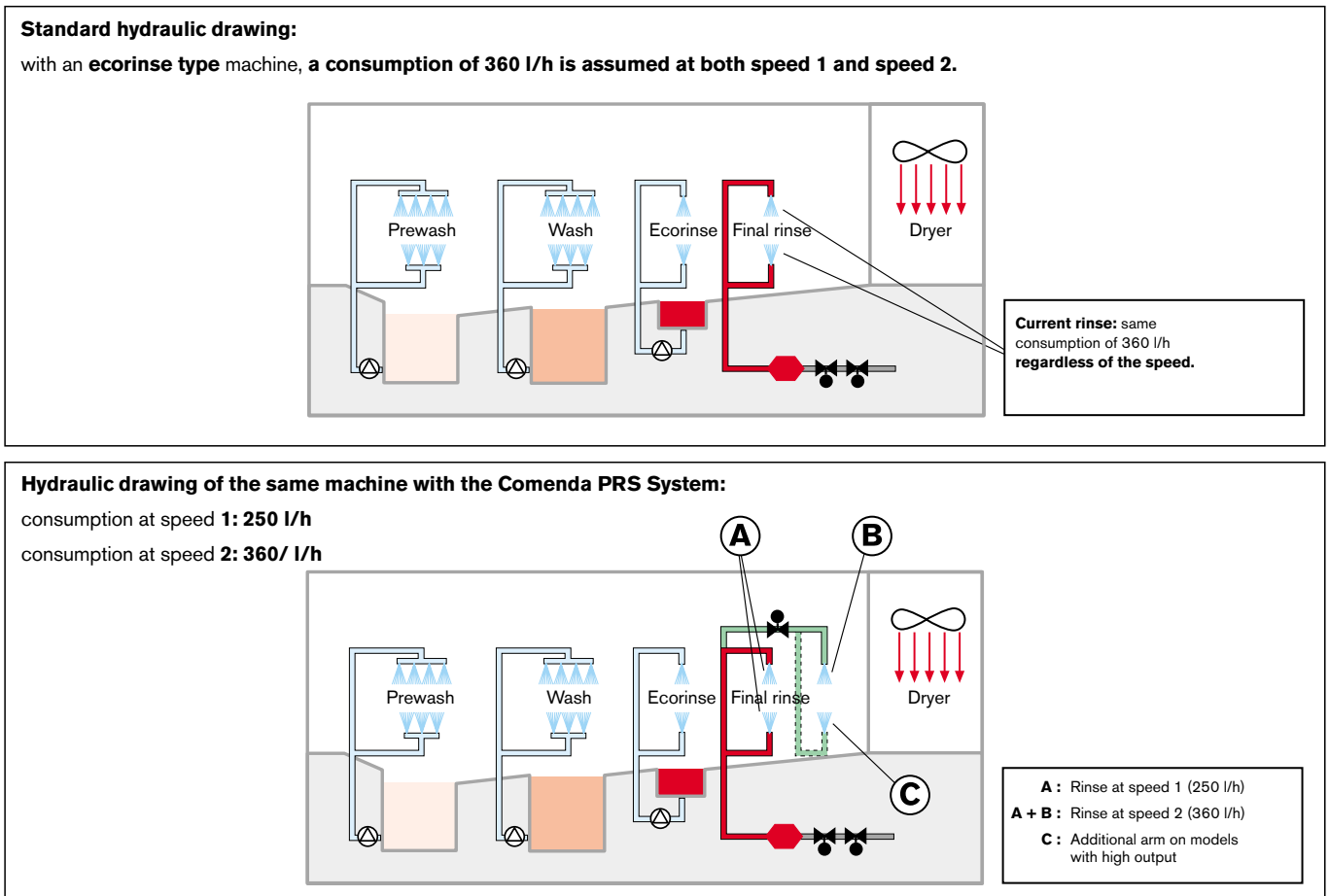

Ali S.p.A.
Via Galileo Galilei 8
20060 Cassina de' Pecchi, Milano
T +39 02 95228.1
F +39 02 9521510
sales@comenda-ali.it
www.comenda-ali.it

900641/3-06

